

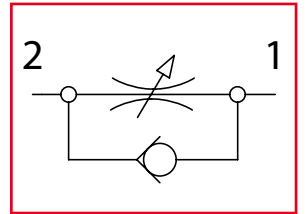

STUF-BSP

Valvole di controllo flusso unidirezionali
Unidirectional flow control valves



Dati tecnici Technical data	
Viscosità fluido Fluid viscosity	10-500 mm ² /s 45 to 2000 ssu (6 to 420 cSt)
Classe di contaminazione Filtration	ISO code 16/13 SAE class 4 or better
Temperatura fluido Fluid temperature	-20°C +80°C -4°F +176°F
Temperatura ambiente Ambient temperature	-20°C +50°C -4°F +122°F

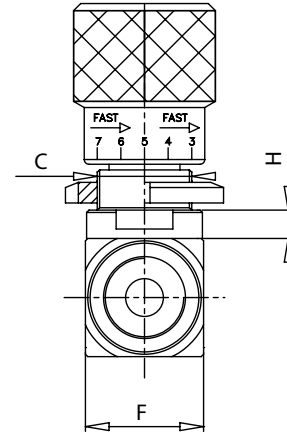
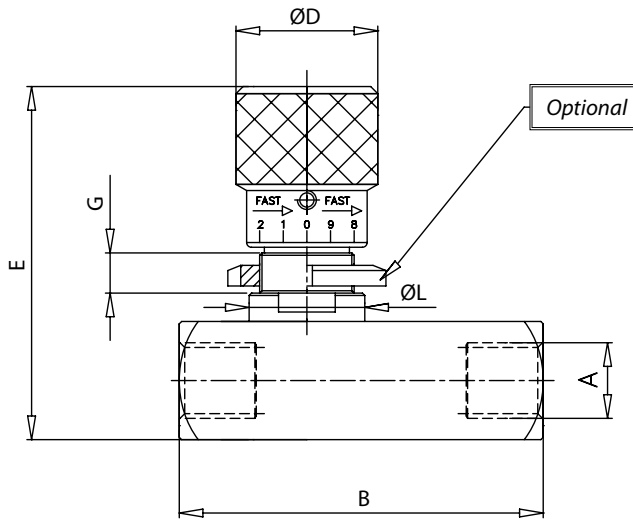
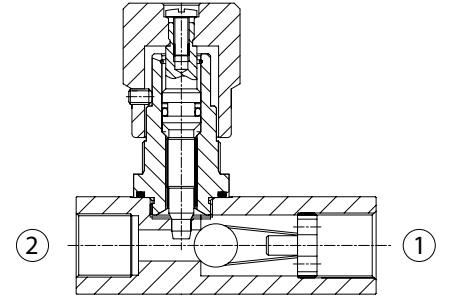

[mm
(Inches)

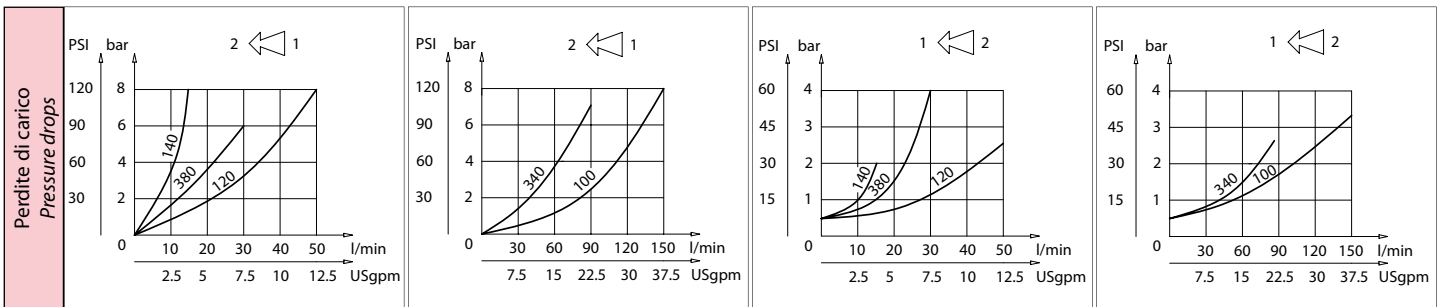

Caratteristiche tecniche Technical performances													Codice ordinazione Ordering code		
Codice Code	A	Portata Max Max flow l/min - USgpm	Pressione Max Max pressure bar/PSI	B	C	D	E	F	G	H	L	Optional Code	Peso approssimativo Approx weight Kg / lb	STUF-X	
													X	Dimensione / Size	
STUF140	BSPP 1/4	15 (4)	400 (5800)	66 (2.60)	M20x1	30 (1.18)	75 (2.95)	25 (0.98)	7,5 (0.29)	6 (0.23)	24,5 (0.96)	84100022	0,38 (0.84)	140	BSPP 1/4
STUF380	BSPP 3/8	30 (8)		77 (3.03)										340	BSPP 3/8
STUF120	BSPP 1/2	50 (13)		91 (3.58)	M25x1,5	33 (1.30)	81 (3.19)	30 (1.18)	9 (0.35)	7 (0.27)	29,5 (1.16)	84100023	0,63 (1.40)	120	BSPP 1/2
STUF340	BSPP 3/4	80 (21)		112,5 (4.43)	M35x1,5	42 (1.65)	110 (4.33)	40 (1.57)	15,5 (0.61)	8 (0.31)	39,5 (1.55)	84100024	1,45 (3.2)	340	BSPP 3/4
STUF100	BSPP 1	150 (40)		141 (5.55)										115 (4.53)	45 (1.77)



STUF-NPTF

Valvole di controllo flusso unidirezionali
Unidirectional flow control valves

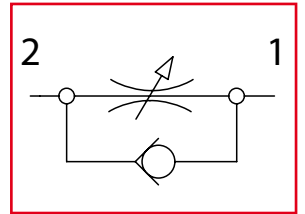

Dati tecnici Technical data	
Viscosità fluido Fluid viscosity	10-500 mm ² /s 45 to 2000 ssu (6 to 420 cSt)
Classe di contaminazione Filtration	ISO code 16/13 SAE class 4 or better
Temperatura fluido Fluid temperature	-20°C +80°C -4°F +176°F
Temperatura ambiente Ambient temperature	-20°C +50°C -4°F +122°F

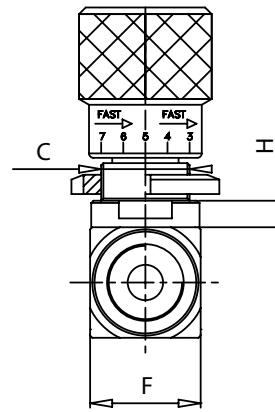
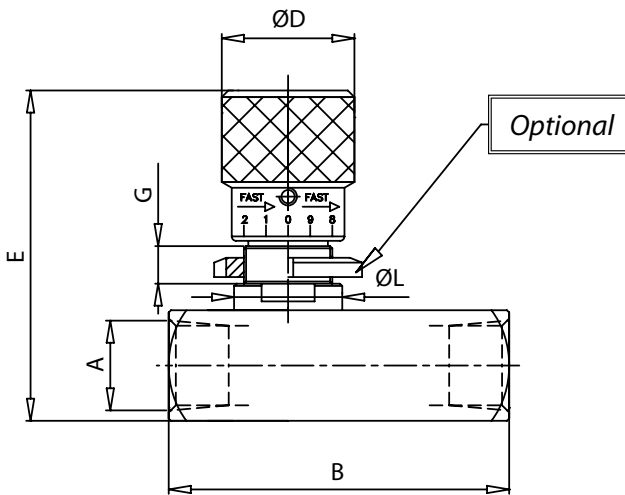
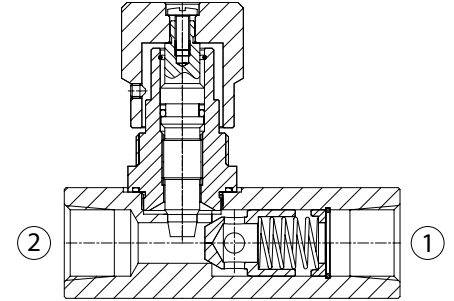

Codice ordinazione Ordering code	
STUF-X-NPTF	
X	Dimensione / Size
140	NPTF 1/4
380	NPTF 3/8
120	NPTF 1/2
340	NPTF 3/4
100	NPTF 1

[mm
(Inches)

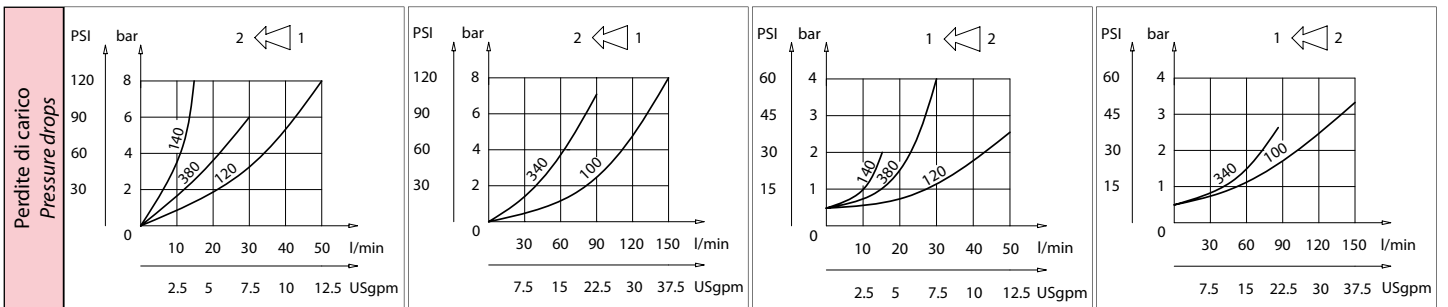

Caratteristiche tecniche Technical performances

Codice Code	A	Portata Max Max flow l/min - USgpm	Pressione Max Max pressure bar/PSI	B	C	D	E	F	G	H	L	Optional Code	Peso approssimativo Approx weight Kg / lb
STUF140NPTF	NPTF 1/4	15 (4)	400 (5800)	66 (2.60)	M20x1	30 (1.18)	75 (2.95)	25 (0.98)	7,5 (0.29)	6 (0.23)	24,5 (0.96)	84100022	0,41 (0.90)
STUF380NPTF	NPTF 3/8	30 (8)		77 (3.03)		30 (1.18)	75 (2.95)	25 (0.98)	7,5 (0.29)	6 (0.23)	24,5 (0.96)		0,42 (0.92)
STUF120NPTF	NPTF 1/2	50 (13)		91 (3.58)	M25x1,5	33 (1.30)	81 (3.19)	30 (1.18)	9 (0.35)	7 (0.27)	29,5 (1.16)	84100023	0,63 (1.38)
STUF340NPTF	NPTF 3/4	80 (21)		112,5 (4.43)	M35x1,5	42 (1.65)	110 (4.33)	40 (1.57)	15,5 (0.61)	8 (0.31)	39,5 (1.55)	84100024	1,52 (3.4)
STUF100NPTF	NPTF 1	150 (40)		141 (5.55)			115 (4.53)	45 (1.77)					2,1 (4.60)



STUF-SAE

Valvole di controllo flusso unidirezionali
Unidirectional flow control valves

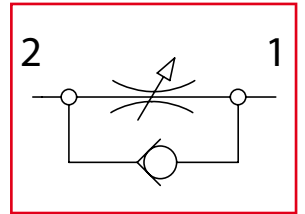

Dati tecnici Technical data	
Viscosità fluido Fluid viscosity	10-500 mm ² /s 45 to 2000 ssu (6 to 420 cSt)
Classe di contaminazione Filtration	ISO code 16/13 SAE class 4 or better
Temperatura fluido Fluid temperature	-20°C +80°C -4°F +176°F
Temperatura ambiente Ambient temperature	-20°C +50°C -4°F +122°F

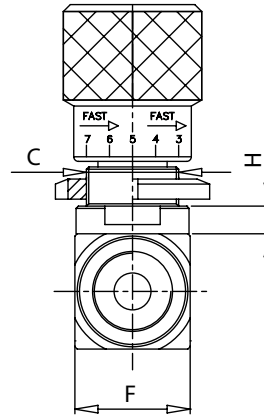
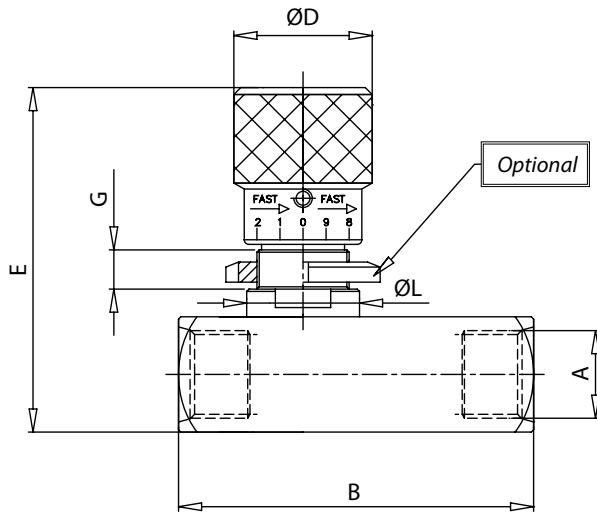
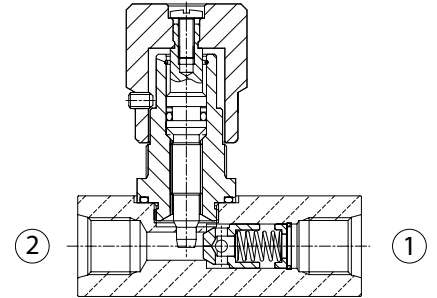

Codice ordinazione Ordering code	
STUF-X-SAE	
X	Dimensione / Size
4	7/16 - 20UNF
6	9/16 - 18UNF
8	3/4 - 16UNF
12	1 - 1/16 - 12UNF
16	1 - 5/16 - 12UNF

[mm
(Inches)]

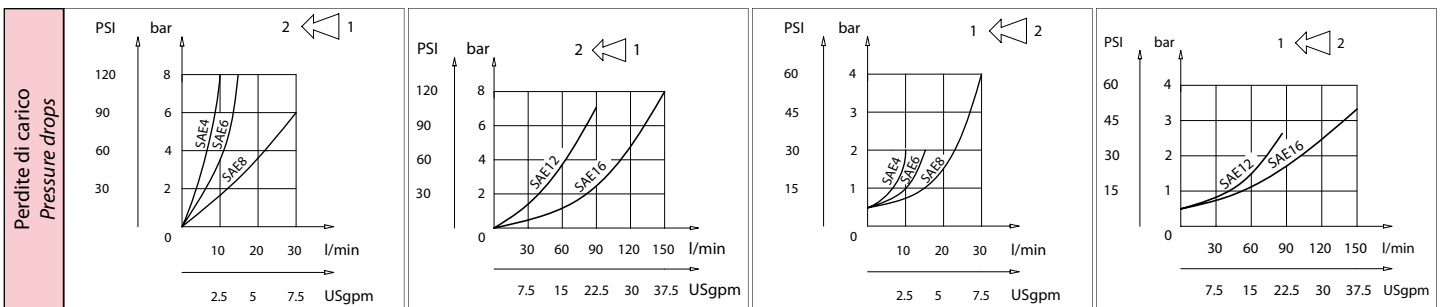

Caratteristiche tecniche Technical performances

Codice Code	A	Portata Max Max flow l/min - USgpm	Pressione Max Max pressure bar/PSI	B	C	D	E	F	G	H	L	Optional Code	Peso approssimativo Approx weight Kg / lb
STUF4SAE	7/16 - 20UNF	15 (4)	400 (5800)	66 (2.60)	M20x1	30 (1.18)	75 (2.95)	25 (0.98)	7,5 (0.29)	6 (0.23)	24,5 (0.96)	84100022	0,41 (0.90)
STUF6SAE	9/16 - 18UNF	30 (8)		70,5 (2.78)									
STUF8SAE	3/4 - 16UNF	50 (13)		91 (3.58)	M25x1,5	33 (1.30)	81 (3.19)	30 (1.18)	9 (0.35)	7 (0.27)	29,5 (1.16)	84100023	0,63 (1.40)
STUF12SAE	1 - 1/16 - 12UNF	80 (21)		112,5 (4.43)	M35x1,5	42 (1.65)	110 (4.33)	40 (1.57)	15,5 (0.61)	8 (0.31)	39,5 (1.55)	84100024	1,40 (3.10)
STUF16SAE	1 - 5/16 - 12UNF	150 (40)		141 (5.55)									